



Project _____

Item No. _____

Quantity _____

EDO 42 SERIES

Electric Deck Pizza Ovens

Model(s) Available

- EDO 42 Single** - Single oven with 36" x 42" cooking surface
- EDO 42 Double** - Double oven with 36" x 42" cooking surface per section
- EDO 42 Triple** - Triple oven with 36" x 42" cooking surface per section



Construction

- 7" (178mm) baking chamber
- 1" thick hearth stone decks
- Moisture vent located at top rear of oven.
- 18 gauge stainless steel exterior front and sides for a beautiful look and durable design
- 18 gauge aluminized steel interiors
- Ultra high temperature fiberglass insulation
- Revolutionary electric coil burner system, ensuring an even distribution of heat throughout the baking deck

Operation

- 300°F - 700°F temperature range
- Infinite top and bottom heat controls

Standard Features

- Four electrical configurations (*must specify when ordering*)
 - 208V, 1 phase
 - 208V, 3 phase
 - 220-240 V, 1 phase
 - 220-240, 3 phase
- Warranty: 1 year labor, 18 months parts

SHORT FORM SPECIFICATIONS: Provide Marsal model EDO 42 (single, double or triple) electric deck oven. Unit shall have 7" (178mm) high baking chamber and 1" thick hearth stone deck. Construction shall be 18 gauge stainless steel exterior front and sides with 18 gauge aluminized steel interiors. Unit shall have ultra high temperature fiberglass insulation. A revolutionary electric coil burner system, ensuring an even distribution of heat throughout the baking deck. A moisture vent shall be located at top rear of the oven. Infinite top and bottom heat controls feature a 300°F - 700°F temperature range. Provide with eighteen month oven parts and one year labor warranty.

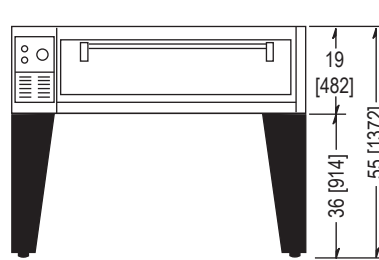

FRONT VIEW - EDO 42 Single

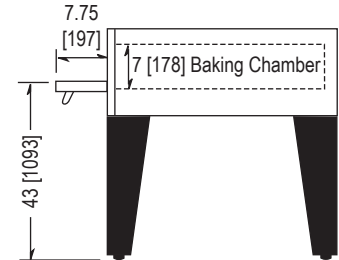

SIDE VIEW - EDO 42 Single

DIMENSIONS ARE IN INCHES [MM]

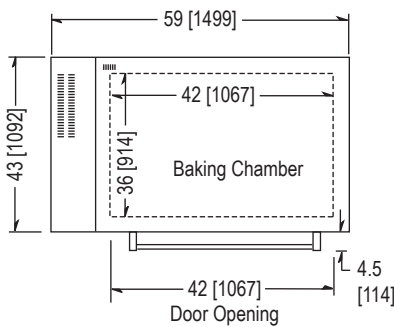

TOP VIEW - All Models

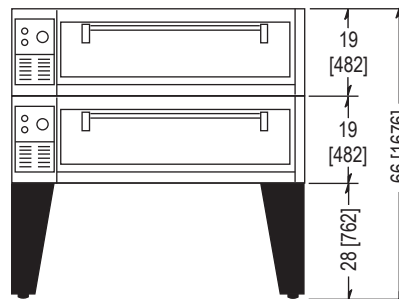

FRONT VIEW - EDO 42 Double

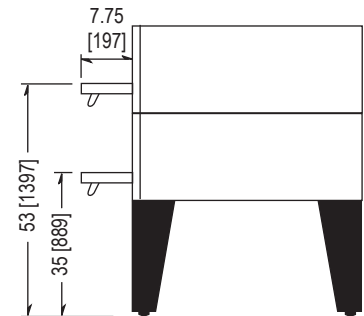

SIDE VIEW - EDO 42 Double

Required Clearances

- 0" on rear and right sides
 - 3" on left side
- (6" on left side is recommended for ease of service)

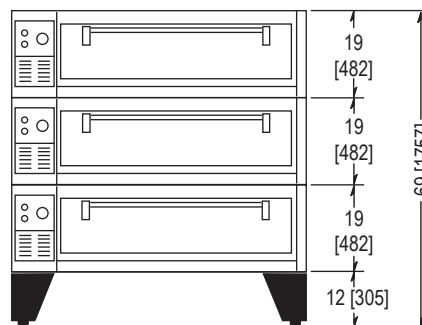

FRONT VIEW - EDO 42 Triple

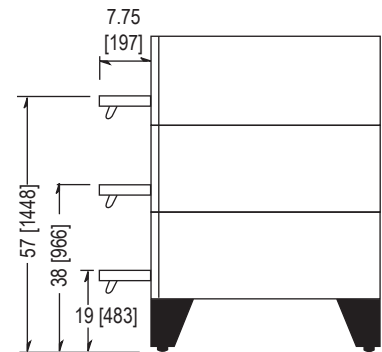

SIDE VIEW - EDO 42 Triple

Specifications

	EDO 42 Single	EDO 42 Double	EDO 42 Triple
Height	55" [1397]	66" [1676]	69" [1757]
Depth & Length	43" x 59" [1092 x 1499]	43" x 59" [1092 x 1499]	43" x 59" [1092 x 1499]
Cooking Surface	36" x 42" [914 x 1067]	36" x 42" [914 x 1067]	36" x 42" [914 x 1067]
# of Decks	1	2	3
Shipping Weight	700 lbs (318 kg)	1390 lbs (630 kg)	2010 lbs (912 kg)

Power Supply (all models)

Watts	8,000	8,000	8,000	8,000
Voltage	208	220-240	208	220-240
Phase	1	1	3	3
Amps	39	35	23	20
Hz	60 or 50			



Copyright 2017 Marsal . All designs and specifications presented in this document are subject to change without notice due to constant innovation.