



Project _____

Item No. _____

Quantity _____

EDO 2136 SERIES Electric Deck Pizza Ovens

Model(s) Available

- EDO 2136 Single** - Single oven with 21" x 36" cooking surface
- EDO 2136 Double** - Double oven with 21" x 36" cooking surface per section
- EDO 2136 Triple** - Triple oven with 21" x 36" cooking surface per section



Construction

- 7" (178mm) baking chamber
- 1" thick hearth stone decks
- Moisture vent located at top rear of oven.
- 18 gauge stainless steel exterior front and sides for a beautiful look and durable design
- 18 gauge aluminized steel interiors
- Ultra high temperature fiberglass insulation
- Revolutionary electric coil burner system, ensuring an even distribution of heat throughout the baking deck

Operation

- 300°F - 700°F temperature range
- Infinite top and bottom heat controls

Standard Features

- Two electrical configurations (*must specify when ordering*)
 - 208V, 1 phase
 - 220-240 V, 1 phase
- Warranty: 1 year labor, 18 months parts

SHORT FORM SPECIFICATIONS: Provide Marsal model EDO 2136 (single, double or triple) electric deck oven. Unit shall have 7" (178mm) high baking chamber and 1" thick hearth stone deck. Construction shall be 18 gauge stainless steel exterior front and sides with 18 gauge aluminized steel interiors. Unit shall have ultra high temperature fiberglass insulation. A revolutionary electric coil burner system, ensuring an even distribution of heat throughout the baking deck. A moisture vent shall be located at top rear of the oven. Infinite top and bottom heat controls feature a 300°F - 700°F temperature range. Provide with eighteen month oven parts and one year labor warranty.

DIMENSIONS ARE IN INCHES [MM]

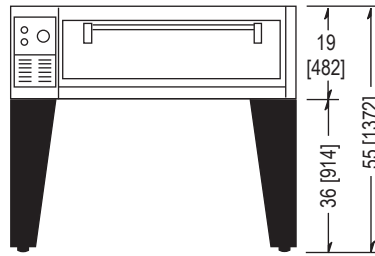

SIDE VIEW - EDO 2136 Single

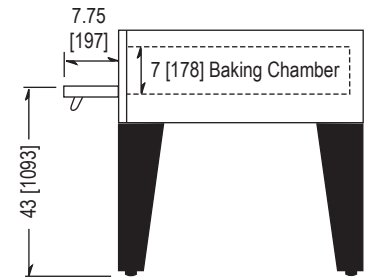

SIDE VIEW - EDO 2136 Single

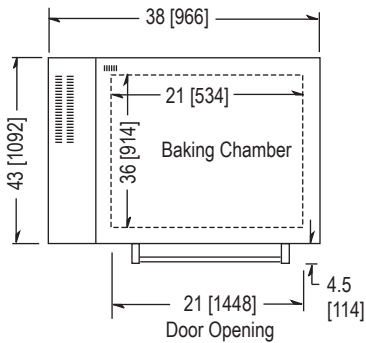

TOP VIEW - All Models

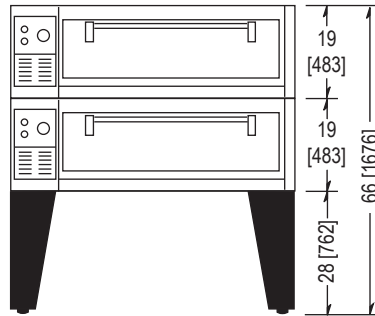

SIDE VIEW - EDO 2136 Double

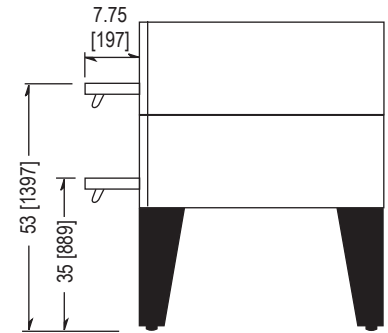

SIDE VIEW - EDO 2136 Double

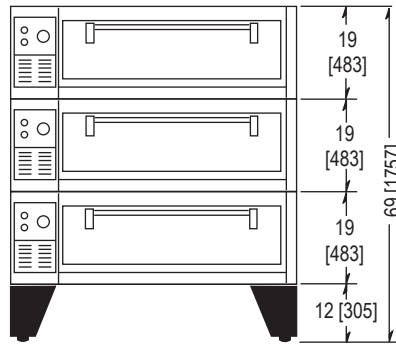

SIDE VIEW - EDO 2136 Triple

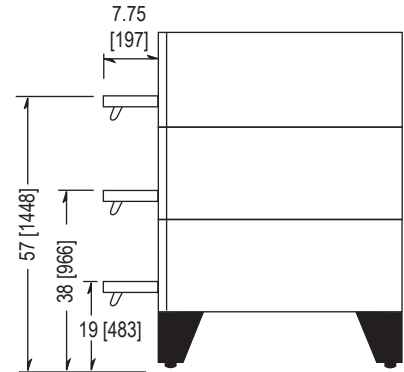

SIDE VIEW - EDO 2136 Triple

Required Clearances

- 0" on rear and right sides
 - 3" on left side
- (6" on left side is recommended for ease of service)

Specifications

	EDO 2136 Single	EDO 2136 Double	EDO 2136 Triple
Height	55" [1397]	66" [1676]	69" [1757]
Depth & Length	43" x 38" [1092 x 966]	43" x 38" [1092 x 966]	43" x 38" [1092 x 966]
Cooking Surface	36" x 21" [914 x 534]	36" x 21" [914 x 534]	36" x 21" [914 x 534]
# of Decks	1	2	3
Shipping Weight	380 lbs (172 kg)	710 lbs (322 kg)	1020 lbs (463 kg)

Power Supply (all models)

Watts	4,000	4,000
Voltage	208	220-240
Phase	1	1
Amps	20	17
Hz	60 or 50	



All designs and specifications presented in this document are subject to change without notice due to constant innovation.